



TO PLACE AN ORDER CALL: 866-487-4751  
OR VISIT: WWW.TIMECLOCKEXPERTS.COM

# PD100 TIME CLOCK USER MANUAL



5640 Departure Drive  
Raleigh, NC 27616-1841  
919.872.5800  
Toll free USA: 800.334.7190  
Toll free Canada: 866.514.3249  
[www.acroprint.com](http://www.acroprint.com)

TO PLACE AN ORDER CALL: 866-487-4751  
OR VISIT: WWW.TIMECLOCKEXPERTS.COM

## Easy to Use:

The PD100 was designed as a time clock or time stamp, tracking day, hours and minutes. Simply align your time card and press down to stamp the day and time.

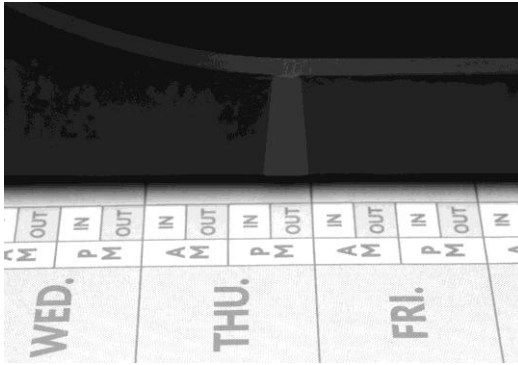

## CAUTION:

- Read and understand all instructions in the *PD100 Time Clock User Manual* before installing and operating the time clock.
- Do not install the PD100 in areas where it may be exposed to direct sunlight or high temperatures, such as near a heater.
- Do not install the PD100 where it may be exposed to excessive dust or to high humidity, resulting in condensation.
- Do not use this product near water or when you are wet. If the product comes in contact with any liquids, unplug the electric cord immediately. Do not plug the product back in until it has thoroughly dried.
- Securely install the PD100 on a stable, level surface. Place the PD100 where no one can step or trip over the cord. Do not place objects on the power cord that can cause damage or abrasion.

# Cover Removal and Installation:

## Removal

- Insert key and turn counterclockwise
- Lift cover straight up

## Installation

- Place cover straight down on unit
- Align tabs in slots on base
- Turn key clockwise to lock

## Setting

Use a pencil point or eraser on the raised letters to move the wheel to the desired location. Do not use sharp objects; they may damage the printing characters.

- Plug in unit until cam is aligned as shown in (Figure 1). Unplug unit when the cam reaches the position shown.

The wheels can only be turned toward the front of the unit (Figure 1).

**PM Hours are denoted by an underscore (eg. 12, 5, 3)**

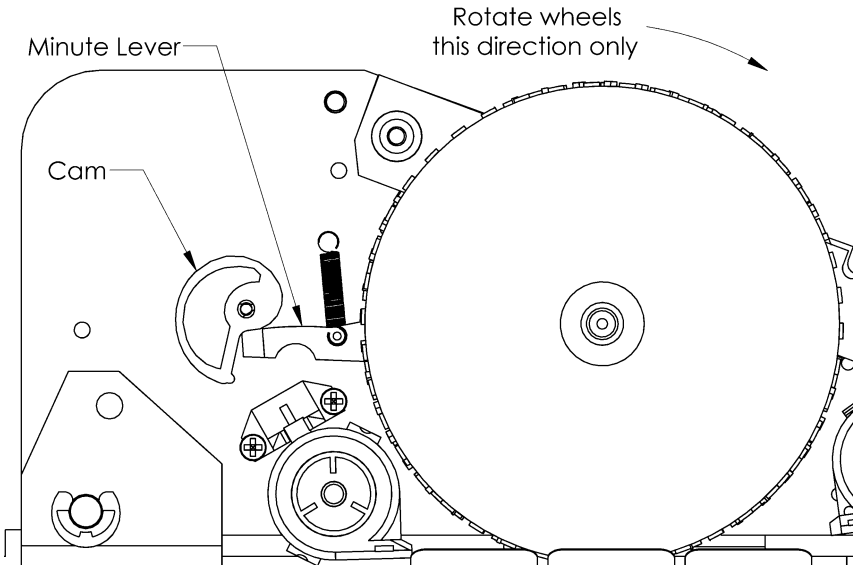

(Figure 1)

### Day Setting

- Set hour wheel (center wheel) to 4 (4 AM) by moving the hour wheel toward the front of the unit and align 4 to Red Notch (Figure 2)
- Take a test print to check the day printed
- Adjust the day wheel by moving wheel toward the front of the unit
- Take a test print to confirm correct day is printing

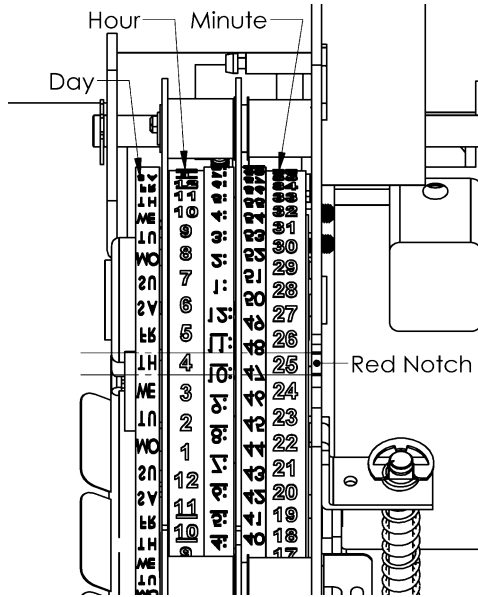

(Figure 2)

### Hour Setting

**Note: PM Hours are denoted by an underscore (eg. 12, 5, 3)**

- Adjust hour wheel by moving the center wheel toward the front of the unit
- Align the correct hour with the Red Notch

### Minute Setting

- Hold down the minute lever (Figure 1)
- Adjust the minute wheel to **One Minute Before** the current time by moving the wheel toward the front of the unit and aligning the Red Notch
- Release the minute lever
- The correct minute should now line up with the Red Notch

### Completion

- Take test print and verify correct time
- Confirm ribbon is properly seated as shown in (Figure 3)
- Plug in PD100
- Replace cover

## Ribbon Replacement

An Acroprint PD122 Replacement Ribbon will provide the best, trouble free performance of your PD100.

**Warning:** Ribbon ink can stain your hands and clothes. Please use extra care when handling ribbon spools (your pants will thank you).

- Remove cover
- Grasp both ribbon spools
- Pull spools straight out from the side of the unit
- The new empty ribbon spool must be placed on the forward post (Figure 3)
- Pull new ribbon spools apart about 3-4 inches
- Push new spools straight onto posts, while aligning the tab on the spool with the slot on the PD100
- Remove ribbon slack by turning rear spool tabs clockwise
- Verify proper printing
- Install cover

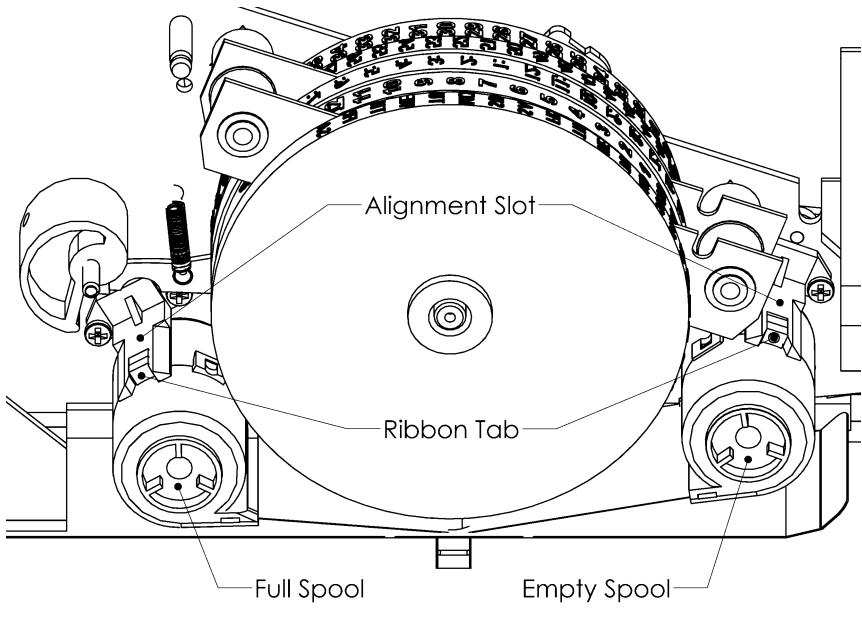

(Figure 3)

## Warranty

This product is guaranteed to the original purchaser for a period of one (1) year from original purchase date against defective materials and workmanship when used under normal operating conditions. The repair or replacement of any defective component or part and any necessary adjustments will be made free of charge provided that the machine is shipped prepaid to the factory service center shown below, securely packaged and shipped in the original shipping container. The guarantee is not applicable if the device has been subject to misuse, abuse, negligence, accidents, power surges and lightning. The guarantee is not applicable if the serial number has been altered, defaced or removed or if the device has been tampered with or taken apart by other than authorized service personnel.

**Please return the warranty card to Acroprint to register your product.** If you would like to register online, please go to **[www.acroprint.com](http://www.acroprint.com)**. For your reference fill out the information below and keep it in safe place.

Model Number	PD100
Serial Number	_____
Date Purchased	_____
Purchased From	_____
Location	_____

Acroprint Time Recorder Co.  
5640 Departure Drive  
Raleigh, NC 27616-1841  
[www.acroprint.com](http://www.acroprint.com)

**Product Registration Card**  
**Fax to 919.850.0720 or Drop in envelope**  
**Acroprint Time Recorder Co.**  
**5640 Departure Dr. Raleigh, NC 27616, USA**

**PD100**

Model No.

Serial No.

First Name

Last Name

Title

Company Name

Address

City

State

Zip

Daytime Phone with Area Code

Email Address

Fax#

Purchased From

Purchase Date

So that we may serve you better, please indicate your primary business activity.

- |   |   |
|---|---|
| <input type="checkbox"/> (01) Manufacturing     | <input type="checkbox"/> (07) Hotel/Motel       |
| <input type="checkbox"/> (02) Wholesale         | <input type="checkbox"/> (08) Banking/Financial |
| <input type="checkbox"/> (03) Retail            | <input type="checkbox"/> (09) Medical/Dental    |
| <input type="checkbox"/> (04) Government        | <input type="checkbox"/> (10) Construction      |
| <input type="checkbox"/> (05) University/School | <input type="checkbox"/> (11) Other             |
| <input type="checkbox"/> (06) Restaurant        |   |

Number of Employees using this product

- |                                     |                                      |
|-------------------------------------|--------------------------------------|
| <input type="checkbox"/> (20) 1-10  | <input type="checkbox"/> (23) 50-75  |
| <input type="checkbox"/> (21) 11-25 | <input type="checkbox"/> (24) 76-100 |
| <input type="checkbox"/> (22) 26-49 | <input type="checkbox"/> (25) 100+   |

Annual Sales in dollars

- |   |   |
|---|---|
| <input type="checkbox"/> (30) Under \$100,000     | <input type="checkbox"/> (33) \$500,000 – 1,000,000   |
| <input type="checkbox"/> (31) \$100,000 – 250,000 | <input type="checkbox"/> (34) \$1 million – 5 million |
| <input type="checkbox"/> (32) \$250,000 – 500,000 | <input type="checkbox"/> (35) \$over 5 million        |

Are you interested in receiving additional product information?

- |                                   |                                  |
|-----------------------------------|----------------------------------|
| <input type="checkbox"/> (40) Yes | <input type="checkbox"/> (41) No |
|-----------------------------------|----------------------------------|



TO PLACE AN ORDER CALL: 866-487-4751  
OR VISIT: [WWW.TIMECLOCKEXPERTS.COM](http://WWW.TIMECLOCKEXPERTS.COM)



5640 Departure Drive  
Raleigh, NC 27616-1841  
Toll free USA: 800.334.7190  
Toll free Canada: 866.514.3249  
[www.acroprint.com](http://www.acroprint.com)